

# DuPont Tyvek<sup>®</sup> Water-Resistive Barriers Installation Guidelines

HELPING YOU GET THE JOB DONE RIGHT



*The miracles of science™*

**VERSION 2**

## Table of Contents

Applicable Products .....	2
Recommended Materials .....	2
Code Requirements.....	3
General Instructions .....	3
Special Considerations .....	3
Installation Instructions.....	4
Continuity	
Terminations .....	6
Gable Ends.....	6
Cantilever Floors.....	6
Penetrations.....	7
Handling Tears and Holes .....	7
Tilt Walls .....	8
DuPont™ Flashing Systems Integration .....	9
Façade Considerations .....	10
Addendum: Use of Temporary Fastening Methods.....	11

## Applicable Products

### Water-Resistive Barriers (WRB)

PRODUCT	DIMENSIONS	AREA
DuPont™ Tyvek® HomeWrap®	3 ft x 100 ft	300 sq ft
	3 ft x 165 ft	495 sq ft
	5 ft x 200 ft	1,000 sq ft
	9 ft x 100 ft	900 sq ft
	9 ft x 150 ft	1,350 sq ft
	10 ft x 100 ft	1,000 sq ft
	10 ft x 150 ft	1,500 sq ft
DuPont™ Tyvek® StuccoWrap®	5 ft x 200 ft	1,000 sq ft
DuPont™ Tyvek® DrainWrap™	9 ft x 125 ft	1,125 sq ft
	10 ft x 125 ft	1,250 sq ft
DuPont™ Tyvek® ThermaWrap™	5 ft x 150 ft	750 sq ft
	9 ft x 100 ft	900 sq ft
DuPont™ Tyvek® CommercialWrap®	5 ft x 200 ft	1000 sq ft
	10 ft x 125 ft	1250 sq ft

### Installation Accessories

PRODUCT	TYPE	QUANTITY
DuPont™ Tyvek® Tape	2" Bulk Pack	36 rolls/case
	3" Bulk Pack Dispenser	24 rolls /case
DuPont™ Tyvek® Metallized Tape	2" x 100' Rolls	12 rolls/case
DuPont™ Tyvek® Wrap Caps for Crossfire® Cap Stapler	16 gauge; available in 7/8", 1-1/4", and 1-1/2" lengths	2000 per box
DuPont™ Tyvek® Wrap Caps for Stinger™ Cap Hammer	16 gauge; 3/8" length	2016 per box

## Recommended Materials

- DuPont™ Tyvek® Water-Resistive Barrier
- DuPont™ Tyvek® Tape
- DuPont™ Tyvek® Wrap Caps or Recommended Fasteners (see step 3)
- DuPont™ Weatherization Sealant or compatible Caulks and Sealants – See the DuPont Building Science Bulletin "Compatibility Guidelines for Building Sealants" for additional guidance

## Water-Resistive Barrier (WRB) Code Requirements

The 2006 International Building Code (Section 1403.2) and the 2006 International Residential Code (Section R703.1) require a water-resistive barrier behind the exterior veneer. This water-resistive barrier must be equivalent to ASTM D226 Type 1 #15 Felt. DuPont™ Tyvek® water-resistive barriers exceed the performance of ASTM D226 felt and are recognized as water-resistive barriers by the following code evaluation reports:

- ICC-ES Legacy Report ER-4000: DuPont™ Tyvek® HomeWrap®, DuPont™ Tyvek® StuccoWrap®, DuPont™ Tyvek® DrainWrap™
- ICC-ES Legacy Report 98-46: DuPont™ Tyvek® HomeWrap®, DuPont™ Tyvek® StuccoWrap®, DuPont™ Tyvek® DrainWrap™
- ICC-ES Legacy Report NER-642: DuPont™ Tyvek® HomeWrap®, DuPont™ Tyvek® StuccoWrap®, DuPont™ Tyvek® DrainWrap™
- ICC-ES Legacy Report 95105D: DuPont™ Tyvek® HomeWrap®, DuPont™ Tyvek® StuccoWrap®, DuPont™ Tyvek® CommercialWrap®
- ICC-ES ESR-1993: DuPont™ Tyvek® ThermaWrap™

## General Instructions

The most effective time to install DuPont™ Tyvek® water-resistive barriers is when:

- walls are constructed
- roof sheathing is installed
- step flashings and kickout flashings are installed
- **BEFORE** the windows and doors are set

If you want to install windows and doors prior to the water-resistive barrier, please refer to the DuPont™ Flashing Systems Installation Guidelines, Flashing **BEFORE** water-resistive barrier section which will direct you back to this guide at the appropriate step.

If the house has windows and doors already installed and they are flashed **be sure to integrate the WRB by following the DuPont™ Flashing Systems Integration section in this guide.**

Note: If DuPont™ FlexWrap™ and apron are used, install the WRB under the apron with DuPont™ Tyvek® and ensure proper shingling. If a non-self adhering sill flashing product is used, please maintain proper shingling.

## Special Considerations

1. DuPont™ Tyvek® StuccoWrap™ and DuPont™ Tyvek® DrainWrap™ shall be installed with drainage grooves vertical, going up and down.
2. To help optimize the installed R-Value benefits of DuPont™ Tyvek® ThermaWrap™ it should be installed with shiny, metallic side facing towards a clear ¾ inch minimum airspace. Without an airspace, DuPont™ Tyvek® ThermaWrap™ will still act as a water-resistive barrier.
3. DuPont requires that DuPont™ Tyvek® HomeWrap®, DuPont™ Tyvek® StuccoWrap®, DuPont™ Tyvek® DrainWrap™ and DuPont™ Tyvek® ThermaWrap™ be covered within 4 months (120 days) of its installation. DuPont™ Tyvek® CommercialWrap® must be covered within 9 months (270 days) of its installation.

## Installation Instructions

Start at the bottom of the structure to ensure proper shingling occurs throughout the installation. Proper shingling is required to provide for water shedding and to prevent water entering the wall system.

### STEP 1

UNWRAP roll at corner, leaving 6" to 12" inches vertical overlap.

Printed stud marks are available on some DuPont™ Tyvek® products to aid in aligning with the studs. (e.g. studmarks are 8" apart for DuPont™ Tyvek® HomeWrap®)

### STEP 2

Roll should be plumb. Bottom edge of roll should extend over sill plate interface at least 2". For maximum air leakage reduction (when installing as an air barrier), seal wrap at the bottom of the wall with sealant (i.e. DuPont™ Weatherization Sealant), DuPont™ Tyvek® Tape, or DuPont™ StraightFlash™. Extend to bottom of sill plate for slab on grade foundations. For stucco exteriors integrate with weep screed.

### STEP 3

Secure DuPont™ Tyvek® water-resistive barrier to the stud. Fasteners should be spaced no closer than 6" and no further than 18" on vertical and horizontal stud lines. Use one or more of the recommended fasteners below for use with DuPont™ Tyvek® water-resistive barriers:

- DuPont™ Tyvek® Wrap Cap nails
- DuPont™ Tyvek® Wrap Cap screws
- DuPont™ Tyvek® Wrap Cap Staples for Stinger™
- 1.0 inch minimum crown staples (except when installing DuPont™ Tyvek® over foam sheathing)

Please see the Addendum: Use of Temporary Fastening Methods in this guide for more information on alternative fastening schedules and requirements.

Note: Do not fasten within 9" of rough opening head.

### STEP 4

Unroll directly over windows and doors. Upper layer of water-resistive barrier should overlap bottom layer of WRB by a minimum of 6".

Refer to the DuPont™ Flashing Systems Installation Guidelines to prepare and flash window and door opening.

Note: If windows are already installed, the DuPont™ Tyvek® water-resistive barrier shall be integrated with proper shingling with window flashings. If DuPont™ FlexWrap™ and apron are used, install the water-resistive barrier under the apron to ensure proper shingling. If non-self adhering sill flashing is used, install the water-resistive barrier under the bottom of the sill flashing to maintain proper shingling.

### STEP 5

All vertical seams shall be taped with DuPont™ Tyvek® Tape.

- For maximum air penetration resistance, when installing as an air barrier, all horizontal seams shall also be taped.

Taping all vertical and horizontal seams, and taping or sealing all terminations (including, but not limited to, roof-wall interfaces and sill plates) is part of the requirement to obtain the DuPont™ Tyvek® Products Material and Labor Residential 10-year Limited Warranty.

Recommend three inch (3") DuPont™ Tyvek® Tape when taping horizontal laps for DuPont™ Tyvek® StuccoWrap™ and DuPont™ Tyvek® DrainWrap™. DuPont™ Tyvek® Metallized Tape is required for taping DuPont™ Tyvek® ThermaWrap™.

### STEP 6

After water-resistive barrier is installed refer to the DuPont™ Flashing Systems Installation Guidelines to prepare and flash windows and doors.

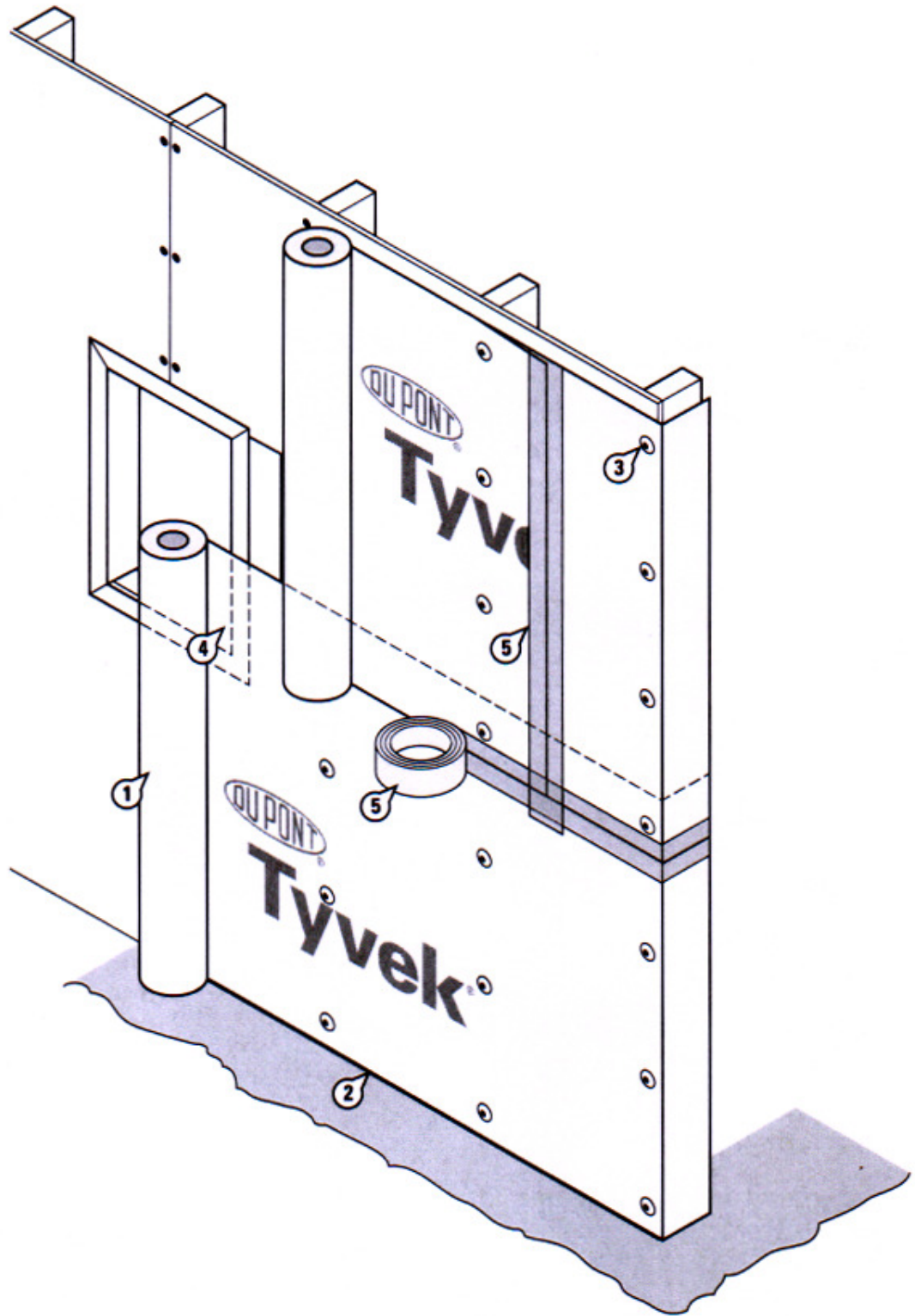

## Continuity

### Terminations

It is important to maintain the continuity of the water-resistive barrier from top to bottom with proper shingling. Continue wrapping all the way up the structure. The entire wall surface shall be wrapped, including unconditioned spaces.

Lap DuPont™ Tyvek® over all flashing (e.g. wall to roof intersections and thru-wall flashings).

Weep screeds and expansion joints need to be integrated with flashings and the water-resistive barrier.

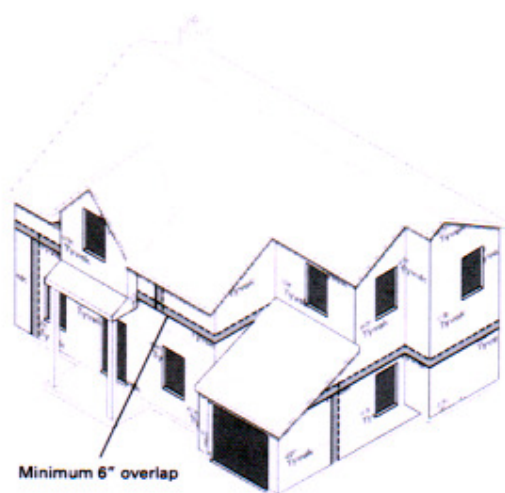
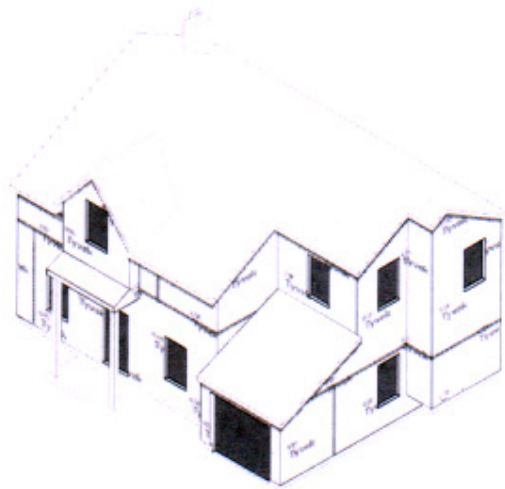

### Gable Ends

Continue to wrap and cut away the excess WRB to completely cover the Gable End.

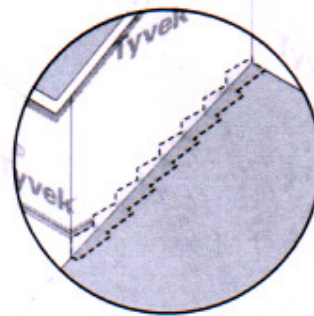
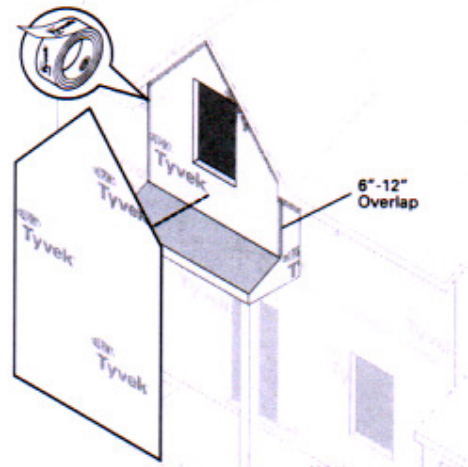

**Lap DuPont™ Tyvek® over all flashing (e.g. wall to roof intersections and thru-wall flashings).**

### Cantilever Floors

Wrap the DuPont™ Tyvek® under and up the Cantilever floor and fold the DuPont™ Tyvek® up the sides of the Cantilever wall a minimum of 6". Tape all corners. Top layer of WRB should go over bottom layer a minimum of 6".

Note: Get the inside corner as tight as possible using a 1x4 or similar.

### Penetrations

There are many types of penetrations including dryer vents, bathroom exhaust fans, exterior electrical outlets, exterior lights, gas lines, etc.

Seal the DuPont™ Tyvek® around all electrical, HVAC and plumbing penetrations with DuPont™ Weatherization Sealant, DuPont™ Tyvek® Tape, or DuPont™ Flashing Systems products.

Start taping or flashing at bottom of penetrations, shingling upper tape over bottom tape.

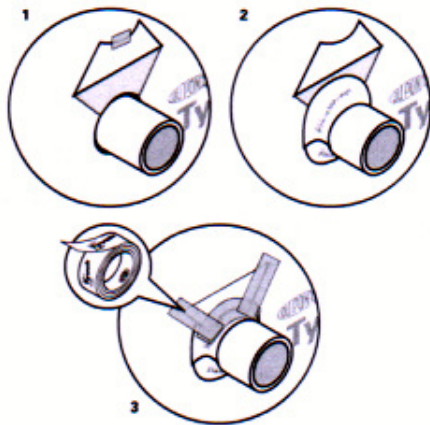

Products that have flanges should be integrated into the water-resistive barrier using DuPont™ Tyvek® Tape or DuPont™ Flashing Systems products.

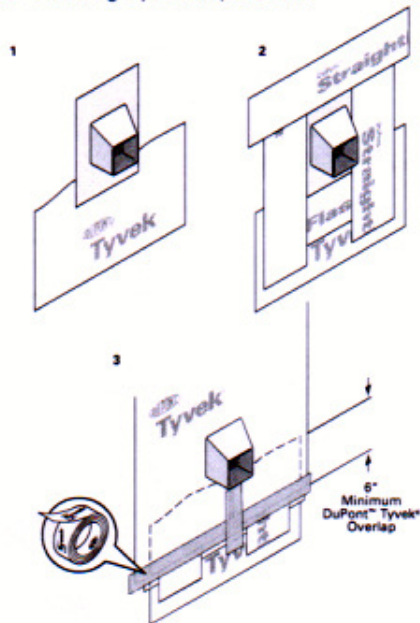

### Handling Tears and Holes

During the course of installing the WRB, minor tears may occur. Be sure to tape all tears. Tears can easily be covered with DuPont™ Tyvek® Tape (2" or 3") or DuPont™ Flashing Systems products.

Larger holes (greater than 1") may require you to cut a piece of DuPont™ Tyvek® WRB to cover the hole. Keep in mind shingling.

Make a cut 2" above the hole and extending a minimum of 2" on each side of the hole. Measure and cut a piece of DuPont™ Tyvek®. Tuck the cut piece of DuPont™ Tyvek® underneath the tear. Tape along the perimeter by starting at bottom of tear, shingling Upper tape over bottom tape.

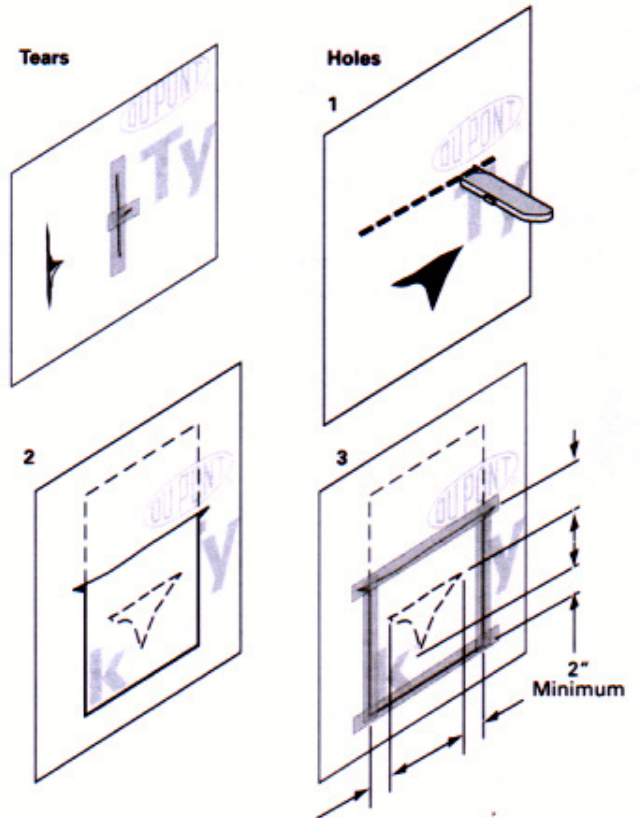

## Tilt Wall Instructions

**STEP 1** Unroll and secure DuPont™ Tyvek® WRB over the wall section. Leave enough lap to ensure a minimum 6" overlap of the WRB on all sides except top of the wall. These flaps allow for a DuPont™ Tyvek®-to-DuPont™ Tyvek® seal with adjacent sides. Make sure the stud marks printed on the DuPont™ Tyvek® line up with the first stud and that the roll is plumb.

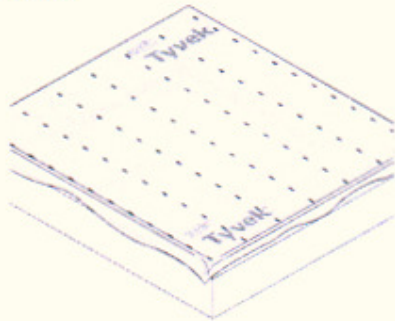

**STEP 2** When starting a wall section, fold the beginning side flap over the vertical side of the stud and secure. Trim off excess. Ensure that the bottom flap overhangs enough so that, when the wall is tilted upright, it overlaps the sill plate.

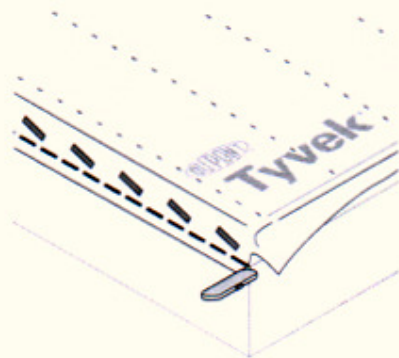

**STEP 3** As each wall section is raised, ensure that the bottom flaps overlap the sill plate and that the side flaps are on the exterior of the house.

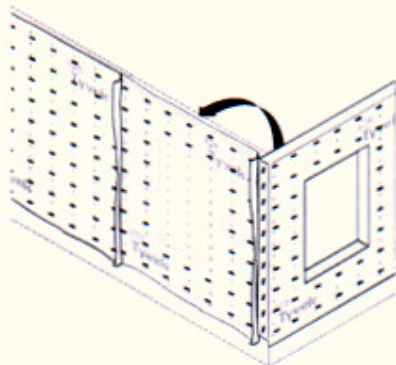

**STEP 4** Fasten the side flaps and secure the bottom flap to the foundation. For maximum air leakage reduction (when installing as an air barrier), seal wrap at the bottom of the wall with DuPont™ Weatherization Sealant, DuPont™ Tyvek® Tape or DuPont™ StraightFlash™.

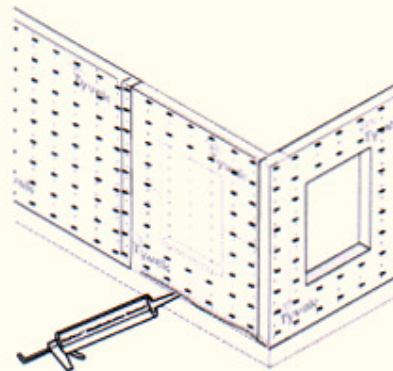

**STEP 5** All vertical seams shall be taped with DuPont™ Tyvek® Tape. For maximum air penetration resistance, when installing as an air barrier, all horizontal seams shall also be taped.

Taping all vertical and horizontal seams is part of the requirement to obtain the DuPont™ Tyvek® Products Material and Labor Residential 10-year Limited Warranty.

Recommend three inch (3") DuPont™ Tyvek® Tape when taping horizontal laps with DuPont™ Tyvek® StuccoWrap® and DuPont™ Tyvek® DrainWrap™. DuPont™ Tyvek® Metallized Tape is required for taping DuPont™ Tyvek® ThermaWrap™.

**STEP 6** After water-resistive barrier is installed refer to the DuPont™ Flashing Systems Installation Guidelines to prepare and flash windows and doors.



## DuPont™ Flashing Systems Integration

If windows and doors have not been installed reference the DuPont™ Flashing Systems Installation Guidelines to prepare the rough opening.

If windows and doors are already flashed, then follow these last 2 integration steps to tie the water-resistive barrier into the flashing.

### STEP 1

- A. Verify that the water-resistive barrier is properly shingled with the bottom of the apron.
- B. Cut as shown to expose window and apron. **DO NOT CUT THROUGH DUPONT™ FLEXWRAP™ OR APRON.**

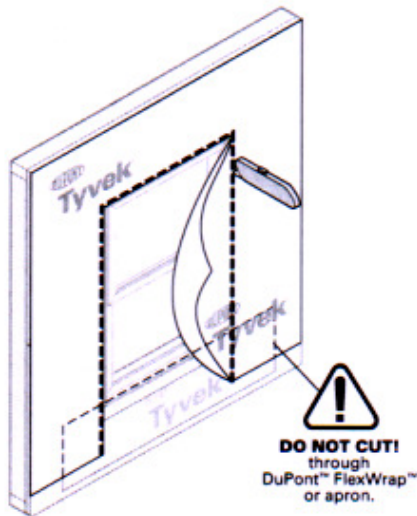

### STEP 2

- A. Tape all seams as shown. **DO NOT TAPE** at bottom of window.
- B. At the head, continuous tape seams as shown with DuPont™ Tyvek® Tape; if an air barrier is not required or if additional drainage is desired, then skip-tape at the head.

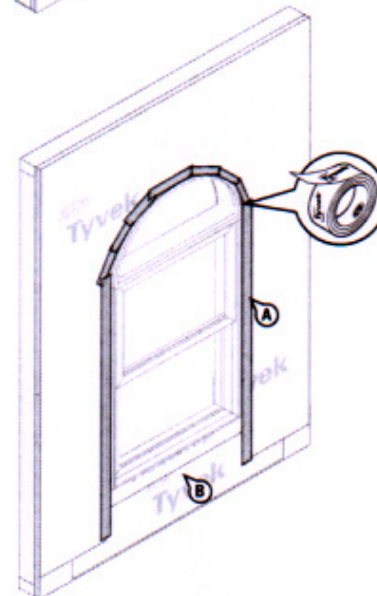
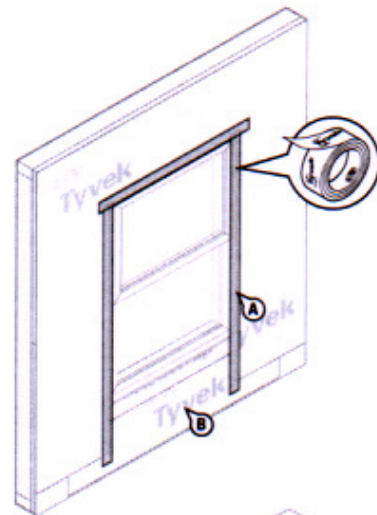

# DuPont™ Tyvek® Water-Resistive Barriers Installation Guidelines

## Façade Considerations

Water-resistive barrier performance is dependent upon the ability of the façade to drain. You must consider the following for specific façades.

### Stucco

When stucco is installed over wood-based sheathing the 2006 International Building Code (Section 2510.6) and the 2006 International Residential Code (Section R703.6.3) require "a water-resistive vapor-permeable barrier with a performance at least equivalent to two layers of Grade D paper" or a layer of water-resistive barrier which is separated from the stucco by an "intervening layer". When two layers are required by code and DuPont™ Tyvek® water-resistive barriers are used behind stucco they should be separated from the stucco by a second layer of DuPont™ Tyvek® water-resistive barrier, a layer of Grade D building paper, felt, rigid foam board or the paper backing of paper-backed lath. The first layer (directly over sheathing or studs) serves as the wall system's water-resistive barrier and is integrated with window and door flashings, the weep screed at the bottom of the wall and any through-wall flashings or expansion joints. Lath shall be installed over the intervening layer in accordance with ASTM C1063-03 Standard Specification for Installation of Lathing and Furring to Receive Interior and Exterior Portland Cement-Based Plaster and applicable codes. Rigid foam board, when installed over DuPont™ Tyvek® water-resistive barrier as an intervening layer, will provide enhanced structural support to the DuPont™ Tyvek® layer and if installed within 24 hours of the DuPont™ Tyvek® layer may reduce the required number of fasteners used for the attachment of the DuPont™ Tyvek® water-resistive barrier.

### Brick

The 2006 International Residential Code (Section R703.7.4.2) requires a nominal 1 inch airspace separating the brick from the water-resistive barrier. The Brick Industry Association recommends a 1 inch air-space in front of wood stud construction and a 2 inch air-space in front of steel stud construction. Consistent with these requirements and recommendations, DuPont™ Tyvek® water-resistive barriers shall be separated from the brick veneer by a nominal 1 inch air-space. Window and door flashing, and through-wall flashing shall be integrated with the DuPont™ Tyvek® layer ensuring proper shingling. For maximum moisture management and drying of the wall system the airspace in front of the DuPont™ Tyvek® shall be vented to the exterior at the top and bottom of the wall. Some types of brick ties will act as additional fasteners for water-resistive barriers, and, if installed within 24 hours of the DuPont™ Tyvek® layer may reduce the required number of fasteners used for the initial attachment of the DuPont™ Tyvek® water-resistive barrier.

### Stone Veneer

The 2006 International Building Code (Section 1405.6) requires two layers of water-resistive barrier behind stone (natural, manufactured, synthetic) veneers over wood frame construction. When two layers are required by code and DuPont™ Tyvek® water-resistive barriers are used behind stucco, they should be separated from the stone and mortar by a second layer of DuPont™ Tyvek® water-resistive barrier, a layer of grade D building paper, felt, rigid foam board or the paper backing of paper-backed lath. The first layer (directly over sheathing or studs) serves as the wall system's water-resistive barrier and shall be integrated with window and door flashings, the weep screed at the bottom of the wall and any through-wall flashings or expansion joints.

### Wood Siding

DuPont™ Tyvek® water-resistive barriers and wood siding shall be installed according to manufacturer's instructions, industry standards and applicable codes. As recommended by the Western Red Cedar Lumber Association and U. S. Forest Product Laboratory, wood siding should be primed on all six sides before installation. In high exposure installations, enhanced drainage and water management may be provided by using DuPont™ Tyvek® DrainWrap™, by installing a drainage mesh over the water-resistive barrier or by creating rainscreen cladding with a larger airspace behind the siding using furring strips. If furring is installed over DuPont™ Tyvek® water-resistive barrier to create a rainscreen, the primary fastener spacing can exceed 18".

### Fiber Cement Siding

DuPont™ Tyvek® water-resistive barriers and fiber cement siding shall be installed according to manufacturer's instructions, industry standards and applicable codes. In high exposure installations, enhanced drainage and water management may be provided by using DuPont™ Tyvek® DrainWrap™ by installing a drainage mesh over the water-resistive barrier or by creating rainscreen cladding with a larger airspace behind the siding using furring strips. If furring is installed over DuPont™ Tyvek® water-resistive barrier to create a rainscreen, the primary fastener spacing can exceed 18".

### Vinyl Siding

Vinyl Siding is installed directly over DuPont™ Tyvek® water-resistive barriers. Vinyl siding shall be installed in accordance with manufacturer's instructions, industry standards and applicable codes, including ASTM D4756-06 Standard Practice for Installation of Rigid Poly(Vinyl Chloride) (PVC) Siding and Soffit.

## DuPont™ Tyvek® Water-Resistive Barrier Residential Installation Guide Addendum: Use of Temporary Fastening Methods

Fastener selection and fastening schedule is a function of holding power during exposure and durability while in service. DuPont installation guidelines require the use of cap fasteners (nail, staple and screw) and 1" crown staples as the means for permanently attaching DuPont™ Tyvek® water-resistive barriers. In addition to fastener selection, DuPont requires a permanent fastener schedule between 6 to 18 inches, anchored to the studs.\* These fasteners and schedule are considered a permanent means of attachment and provide substantial holding power during exposure and in the case of cap fasteners, provide additional protection against moisture and air infiltration at the fastener locations particularly for cladding applications that are in intimate contact with the water-resistive barrier or provide minimal drainage. These fastening guidelines minimize the number of penetrations while maintaining a balance of product durability during exposure. Sheathing, except for structural OSB and structural plywood, is not a fastening base and should not be relied on as the fastening base. This includes but is not limited to foam, fiberboard and plaster sheathing materials.

Use of recommended permanent fasteners at reduced schedules, other mechanical fasteners such as smaller staples (slap staples) and adhesives are considered temporary fastening methods because they do not have substantial holding power and may not provide adequate durability while in service. Temporary fasteners should not be relied upon to permanently attach a water-resistive barrier. Because these fasteners have limited holding power, they are not supported by DuPont as the primary means of attachment.

Temporary fastening methods can be used if the following guidelines are followed:

- Temporary fastening methods shall only be used to tack the DuPont™ Tyvek® in place when a permanent fastener is installed immediately after the temporary fasteners are installed. In this case, permanent fasteners include cladding fasteners such as brick ties, lath fasteners for traditional stucco, external foam board fasteners, or siding installed with nails. Cladding shall be installed according to applicable building codes and industry standards.
- When using adhesives, vertical strips are acceptable spaced approximately every 24 to 36 inches or along every other stud line. Vertical strips may be applied at the sheathing outer face or directly to the studs for open stud construction. When using adhesives, care must be taken to not cover the surface excessively since this may impact the vapor permeability of the wall system in that region. Adhesives should be evaluated for compatibility to DuPont™ Tyvek® water-resistive barriers.
- When using temporary mechanical fasteners, they should be used minimally to tack the water resistive barrier in place. Small staple fasteners are acceptable with OSB, plywood and exterior gypsum sheathing only. Small staple fasteners should not be used with fiberboard or foam sheathing. Temporary fastener schedule should not exceed 4 fasteners per square yard. Tape all tears and localized damage. For larger holes (greater than 1") follow DuPont™ Tyvek® Water-Resistive Barriers Installation Guidelines.
- Only capped temporary fasteners shall be used with 3-coat stucco and stone veneer applications unless an intervening layer is used.

Selection and use of temporary fastening methods is an option dependent on building schedule, cladding options and local building practices. If temporary fasteners are used per this guideline, DuPont will provide a 10-yr limited product replacement or materials and labor warranty.\*\*

\* For more detail on installation guidelines, please refer to the DuPont™ Tyvek® Water-Resistive Barriers Installation Guidelines at [www.construction.tyvek.com](http://www.construction.tyvek.com).

\*\* For more detail on the DuPont 10-yr limited product replacement or materials and labor warranty, please refer to the DuPont 10-yr limited product replacement or materials and labor warranties detailed at [www.Construction.Tyvek.com](http://www.Construction.Tyvek.com).

Note: These Temporary Fastening Guidelines are subject to change based on new technology or testing information and may be superseded at any time. It is always important to follow the latest guidelines which may be found on [www.construction.tyvek.com](http://www.construction.tyvek.com).

## Technical Specifications

DuPont™ Tyvek® WRBs used in construction products is made from 100% flash spunbonded high density polyethylene fibers which have been bonded together by heat and pressure, without binders or fillers, into a tough, durable sheet structure. Additives have been incorporated into the polyethylene to provide ultraviolet light resistance. DuPont requires that DuPont™ Tyvek® WRBs be covered within four months (120 days) of installation.

DuPont™ Flashing Systems products are made from a synthetic rubber adhesive and a laminate of polyethylene film, elastic fiber, synthetic rubber adhesive, polyurethane adhesive, and a top sheet of flash spunbonded high density polyethylene fibers. Additives have been incorporated into these materials to provide ultraviolet light resistance. DuPont requires that DuPont™ Flashing Systems products be covered within four months (120 days) of installation.

## Warning

**DuPont™ Tyvek® WRBs are slippery and should not be used in any application where it will be walked on. In addition, because it is slippery, DuPont recommends using kickjacks or scaffolding for exterior work above the first floor. If ladders must be used, extra caution must be taken to use them safely by following the requirements set forth in ANSI Standards 14.1, 14.2 and 14.5 for ladders made of wood, aluminum, and fiberglass, respectively. DuPont™ Tyvek® is combustible and should be protected from a flame and other high heat sources. DuPont™ Tyvek® will melt at 275°F (135°C) and if the temperature of DuPont™ Tyvek® reaches 750°F (400°C), it will burn and the fire may spread and fall away from the point of ignition. For more information, call 1-800-44-Tyvek.**

**DuPont™ Flashing Systems products and their release paper are slippery and should not be walked on. Remove release paper from work area immediately. DuPont™ Flashing Systems products will melt at temperatures greater than 250°F (121°C). DuPont™ Flashing Systems products are combustible and should be protected from flame and other high heat sources. DuPont™ Flashing Systems products will not support combustion if the heat source is removed. However, if burning occurs, ignited droplets may fall away from the point of ignition. For more information, call 1-800-44-Tyvek.**

**DuPont™ Weatherization Sealant is irritating to skin, eyes, and respiratory tract. For proper usage, follow directions stated on the product label. For health information, refer to the Material Safety Data Sheet or call Chemtrec at 1-800-424-9300.**

## Note

When installed in conjunction with other building materials, DuPont™ Flashing Systems products must be properly shingled with these materials, such that water is diverted to the exterior of the wall system. DuPont™ Tyvek® products are WRBs and not the primary water barrier (the outer facade is the primary barrier). You must follow façade manufacturer's installation and maintenance requirements for all façade systems in order to maintain water holdout properties and ensure performance of DuPont™ Tyvek®. Use of additives, coatings or cleansers on or in the façade system may impact the performance of DuPont™ Tyvek® water-resistive barriers. DuPont™ Tyvek® Weatherization Systems products are to be used as outlined in this installation guideline. DuPont™ Flashing Systems products should only be used to seal penetrations and flash openings in houses or buildings. DuPont™ Flashing Systems products are not to be used in roofing applications. For superior protection against bulk water penetration, DuPont suggests a system combining a quality exterior facade, a good secondary WRB, an exterior sheathing, appropriate flashing materials and details. In addition, DuPont suggests to use high quality windows and doors with particular attention to proper installation of each component. In a system where no exterior sheathing is used and DuPont™ Tyvek® is installed directly over the wall studs, exterior facade materials should be selected to ensure maximum protection against water intrusion. Careful workmanship and proper installation of each component is very important.

DuPont believes this information to be reliable and accurate. The information may be subject to revision as additional experience and knowledge is gained. It is the user's responsibility to determine the proper construction materials needed.

For complete warranty information, please call 1-800-44-Tyvek. To submit a warranty claim, please contact DuPont at [www.Construction.Tyvek.com](http://www.Construction.Tyvek.com) or call 1-800-44-Tyvek. Warranty coverage requires submission of proof of purchase of the DuPont™ Tyvek® at issue.

This information is not intended to be used by others for advertising, promotion or other publication for commercial purposes.

For more information about DuPont™ Tyvek® Weatherization Systems, please call 1-800-44-Tyvek or visit us at [www.Construction.Tyvek.com](http://www.Construction.Tyvek.com)



*The miracles of science™*

DuPont™  
**Tyvek®**